

## TECHINICAL SPECIFICATIONS

MODEL	STANDARD	WIRES (No.)	LENGTH (mm)	WEIGHT (Kg)
VZS2351-101-2804	NEMA 23	4	51	0.6

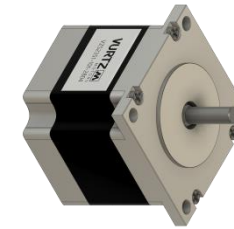

CONNECTION	HOLDING TORQUE (Kgf.cm)	DETENT TORQUE (gf.cm)	ROTOR INERTIA (gf.cm <sup>2</sup> )	CURRENT (A/Phase)	VOLTAGE (V/Phase)	RESITANCE (Ω/Phase)	INDUTANCE (mH/Phase)
BIPOLAR	10.1	300	230	2.8	2.3	0.83 ±10%	2.2 ±20%
UNIPOLAR	N/A	N/A	N/A	N/A	N/A	N/A	N/A

## GENERAL SPECIFICATION

STEP ANGLE	INSULATION RESISTENCE	DIELETRIC STRENGTH	TEMPERATURE RISE	AMBIENT TEMPERATURE	MAXIMUM RADIAL CLARENCE	MAXIMUM AXIAL CLARENCE	RADIAL FORCE	AXIAL FORCE
1.8° ±5%	100MΩ MIN, 500V DC	500 VAC / 1 MIN	80 °C (MAX)	-20°C ~ +50°C	0.02mm (450G LOAD)	0.08mm (450G LOAD)	75N (MAX)	15N (MAX)

**WIRING DIAGRAM**

BIPOLAR	
MOTOR	DRIVER
BLACK (A)	A+
GREEN (C)	A-
RED (B)	B+
BLUE (D)	B-

STEP (CW)	A	B	C	D
1	+	+	-	-
2	-	+	+	-
3	-	-	+	+
4	+	-	-	+

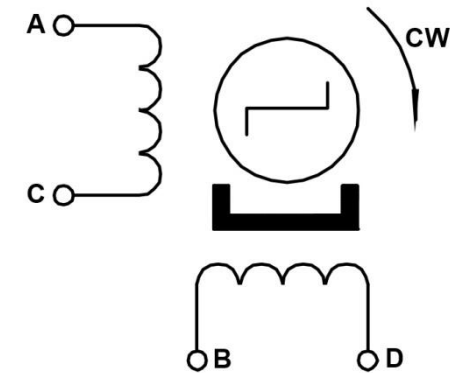

UNIPOLAR	
MOTOR	DRIVER
N/A	N/A
N/A	N/A
N/A	N/A
N/A	N/A

STEP (CW)	A	B	C	D
N/A	N/A	N/A	N/A	N/A
N/A	N/A	N/A	N/A	N/A
N/A	N/A	N/A	N/A	N/A
N/A	N/A	N/A	N/A	N/A

THIS MOTOR DOES NOT HAVE A UNIPOLAR CONNECTION.

TORQUE CURVE

DRIVER: JK5056S | CURRENT: 2.8A/Ph | VOLTAGE OF DRIVER: 33VDC | STEP/REV: 400 (HALF-STEP)

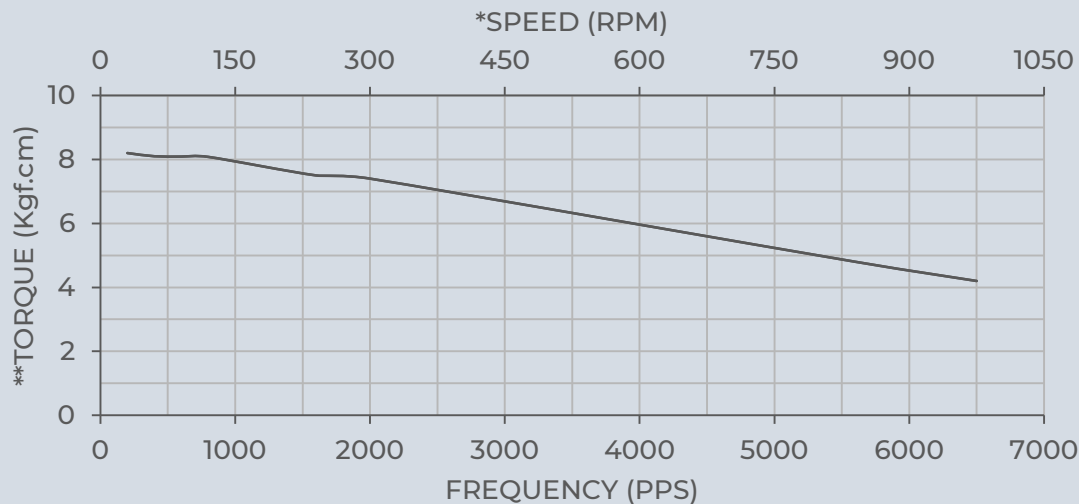

\* THIS GRAPHIC SPEED SCALE IS ONLY CONDITIONED ON THE HALF STEP DRIVER SETING.

\*\*PULL-OUT TORQUE;

NOTE: THE MOTOR SPEED (RPM) VARIES ACCORDING TO 3 VARIABLES, STEP/REV (AMOUNT OF STEP TO COMPLETE 1 LAP), PPS (PULSES PER SECOND) AND THE TYPE STEP OF DRIVER, BEING FULL STEP (1/1), HALF STEP (1/2) AND MICROSTEPPING (1/4, 1/8 AND 1/16). THE SPEED (RPM) CAN BE CALCULATED WITH THE FOLLOWING EQUATIONS:

$$\text{STEP/REV} = \left( \frac{360}{\text{ANGLE STEP}} / \text{TYPE STEP OF DRIVER} \right) \quad \text{AND} \quad \text{RPM} = \frac{\text{PPS}}{\text{STEP/REV}} \times 60$$

DIMENSIONS

UNIT: mm

